



**GRAND RENEWABLE ENERGY  
PARK - DRAFT PROJECT  
DESCRIPTION REPORT**

**DRAFT**

File No. 160960577  
June 2010

Prepared for:

**Samsung Renewable Energy Inc.  
55 Standish Court  
Mississauga, ON L5R 4B2**

Prepared by:

**Stantec Consulting Ltd.  
Suite 1 - 70 Southgate Drive  
Guelph ON N1G 4P5**

**Table of Contents**

---

<b>1.0</b>	<b>OVERVIEW.....</b>	<b>1.1</b>
1.1	GENERAL INFORMATION.....	1.1
1.2	CONTACTS.....	1.2
1.3	AUTHORIZATIONS REQUIRED.....	1.2
	1.3.1 Provincial.....	1.2
	1.3.2 Municipal.....	1.3
	1.3.3 Federal Involvement.....	1.4

---

<b>2.0</b>	<b>PROJECT INFORMATION.....</b>	<b>2.1</b>
2.1	ENERGY SOURCES.....	2.1
2.2	LAND OWNERSHIP.....	2.1
2.3	PROJECT COMPONENTS.....	2.1
	2.3.1 Wind Turbine Generators.....	2.1
	2.3.2 Solar Panels.....	2.1
	2.3.3 Electrical Interconnection.....	2.1
	2.3.4 Access Laneways.....	2.2
	2.3.5 Operations and Maintenance Building.....	2.2
2.4	PROJECT SCHEDULE.....	2.2
2.5	PROJECT ACTIVITIES.....	2.3
	2.5.1 Waste Generation and Emissions.....	2.4
	2.5.2 Hazardous Materials.....	2.4
	2.5.3 Sewage and Stormwater Management.....	2.4
	2.5.4 Water-taking Activities.....	2.5

---

<b>3.0</b>	<b>DESCRIPTION OF POTENTIAL ENVIRONMENTAL EFFECTS.....</b>	<b>3.1</b>
<b>4.0</b>	<b>CLOSURE.....</b>	<b>4.1</b>

**List of Tables**

---

Table 1.1	Project Description Report Contents.....	1.1
Table 1.2	Key Provincial Permits and Authorizations.....	1.3
Table 1.3	Key Municipal Permits and Authorizations.....	1.3
Table 1.4	Key Federal Permits and Authorizations.....	1.4
Table 2.1	Project Schedule Overview.....	2.2
Table 2.2	Key Project Activities.....	2.3

## **Table of Contents**

---

### **List of Appendices**

---

- Appendix A Project Location and Study Area
- Appendix B Turbine Specifications
- Appendix C Environmental Features Screening Checklist

**DRAFT**

## 1.0 Overview

This document provides a preliminary description of the proposed Grand Renewable Energy Park (the Project). This Project Description Report has been written in accordance with Ontario Regulation 359/09 (Renewable Energy Approvals under Part V.0.1 of the Act) under the *Environmental Protection Act*. The information provided herein, and its location within the document is as follows:

**Table 1.1 Project Description Report Contents**

<b>Content</b>	<b>Location within Project Description Report</b>
1. Any energy sources to be used to generate electricity at the renewable energy generation facility.	Section 2.1
2. The facilities, equipment or technology that will be used to convert the renewable energy source or any other energy source to electricity.	Section 2.2
3. If applicable, the class of the renewable energy generation facility.	Section 2.3
4. The activities that will be engaged in as part of the renewable energy project.	Section 2.4
5. The name plate capacity of the renewable energy generation facility.	Section 2.5
6. The ownership of the land on which the project location is to be situated	Section 2.6
7. Any negative environmental effects that may result from engaging in the project.	Section 3.0 and Appendix C
8. An unbound, well marked, legible and reproducible map that is an appropriate size to fit on a 215 millimetre by 280 millimetre page, showing the project location and the land within 300 metres of the project location.	Appendix A

### 1.1 GENERAL INFORMATION

The Project is known as the Grand Renewable Energy Park and consists of a 140 MW (nameplate capacity) wind project and a 100 MW (nameplate capacity) solar project. The Project will be entirely located within Haldimand County in south-western Ontario. A map showing the location of the project is provided in **Appendix A**.

The Project area consists of flat, gently rolling farmland. It is generally bounded by i) Haldimand Concession 11 W-1 to the North; ii) Haldimand Road 55 to the West; iii) the Grand River to the East; and iv) Lake Erie to the South. Settlements in the general vicinity of the Project include Selkirk, Fisherville, South Cayuga, and Byng. Selkirk Provincial Park and James N. Allan Provincial Park are also located in the general vicinity of the Project.

## 1.2 CONTACTS

The proponent for the Project is Samsung Renewable Energy Inc. ("Samsung"). Samsung's office and contact for the Project is:

Name: Adam Rosso  
Title: Manager, Business Development  
Company: Samsung Renewable Energy Inc.  
Address: 55 Standish Court  
Mississauga, ON L5R 4B2

The lead consultant for preparation of the Renewable Energy Approval (REA) application is Stantec Consulting Ltd. ("Stantec"). Stantec provides professional consulting services in planning, engineering, architecture, interior design, landscape architecture, surveying, environmental sciences, project management, and project economics for infrastructure and facilities projects. The consultant's office and Project contact is:

Name: Rob Nadolny  
Title: Senior Project Manager  
Company: Stantec Consulting Ltd.  
Address: Suite 1 - 70 Southgate Drive  
Guelph, ON N1G 4P5

Project Email: GrandRenewable@SamsungRenewableEnergy.ca  
Project Telephone: (877) 536-6050 or 519-836-6050 (collect)

## 1.3 AUTHORIZATIONS REQUIRED

### 1.3.1 Provincial

According to subsections 4.(3) and 6.(3) of the Regulation, the proposed solar project is a Class 3 Solar Facility and the wind project is a Class 4 Wind Facility. As agreed upon with the Ministry of the Environment, one REA Application will be submitted for the Project consisting of information related to both the wind and solar projects. In return, two separate Renewable Energy Approvals are being sought, one for the wind project and one for the solar project.

At the provincial level there are multiple permits and approvals that may be required to facilitate the development of the Project, in addition to the REA. Their ultimate applicability will be determined during the REA process and based upon the Project's detailed design. The following is a list of key permits and approvals that may be required; however additional permits may also be required.

**Table 1.2 Key Provincial Permits and Authorizations**

<b>Key Permit / Authorization</b>	<b>Administering Agency</b>	<b>Rationale</b>
Approval of Connection	IESO	Electrical interconnect with IESO regulated network
Connection Assessment	IESO	Integration of project with IESO-controlled transmission system
Customer Impact Assessment	Hydro One Networks Inc. (HONI)	Integration of project with Hydro One and effects to customers
Connection Cost Recovery Agreement (CCRA)	HONI	Recovery of costs to grid operator of changes to allow connection
System Impact Assessment	IESO	Integration of project with IESO-controlled transmission system
Development, Interference with Wetlands, and Alterations to Shorelines and Watercourses Permit	Grand River Conservation Authority and Long Point Conservation Authority	Work within floodplains, water crossings, river or stream valleys, hazardous lands and within or adjacent to wetlands. Projects requiring review, <i>Fisheries Act</i> authorization and/or assessment under the <i>Canadian Environmental Assessment Act</i> are forwarded to the Department of Fisheries and Oceans (DFO)
Certificate of Inspection	Electrical Safety Authority (ESA)	A record that electrical work complies with the requirements of the Ontario Electrical Safety Code.
Generator's License	Ontario Energy Board (OEB)	Generation of electrical power for sale to grid
Leave to Construct	OEB	Authorization to construct power transmission lines
Notice of Project	Ministry of Labour	Notify the Ministry of Labour before construction begins.
Special vehicle configuration permit	Ministry of Transportation (MTO)	Use of non-standard vehicles to transport large components
Transportation Plan	MTO	Adherence to road safety and suitability
Highway Entrance Permit	MTO	Entrance permit for new or upgraded road entrances onto a provincial highway Interference or obstruction of the highway
Change of Access and Heavy/Oversize Load Transportation Permit	MTO	Compliance with provincial highway traffic and road safety regulations
Wide or excess load permit	MTO	Transportation of large or heavy items on provincial highways

### 1.3.2 Municipal

Several permits and authorizations may also be required from Haldimand County (Table 1.3).

**Table 1.3 Key Municipal Permits and Authorizations**

<b>Key Permit / Authorization</b>	<b>Rationale</b>
Municipal Consent, Work with the R.O.W	Required for works in municipal road allowances
Consent/Severance Application	Required if easements over private lands required
Road Cut Permit	May be required for access roads off of county roads or works to county roads
Pre-Condition Survey	Assessment of pre-construction conditions for engineering staff

**Table 1.3 Key Municipal Permits and Authorizations**

<b>Key Permit / Authorization</b>	<b>Rationale</b>
Building Permit	Compliance with building codes
Entrance Permit	Entrance from county roads
Transportation Plan	Adherence to road safety and suitability
Additional Plans related to general engineering (e.g. siltation control, lot grading, plan of services, etc.), water, wastewater, storm water, transportation, and geotechnical	Required supporting information/plans required by Haldimand County

**1.3.3 Federal Involvement**

It is expected that a Federal Screening report will not be required for the Project, as it is not anticipated that it will cause a ‘trigger’ under the *Canadian Environmental Assessment Act* (CEAA), such as a Harmful Alteration, Disruption or Destruction of fish habitat under the *Fisheries Act*, or application for project funding under a future program similar to *ecoEnergy for Renewable Power*. However, the agency consultation program for the Project will include all federal departments and agencies typically interested in wind power projects (e.g., Department of National Defense, Environmental Canada, Transport Canada, etc.). All required federal permits and approvals required for the Project will be determined during the REA process, but may include those listed in Table 1.4.

**Table 1.4 Key Federal Permits and Authorizations**

<b>Permit / Authorization</b>	<b>Administering Agency</b>	<b>Rationale</b>
Aeronautical Obstruction Clearance	Transport Canada – Aviation Division	Turbine lighting and marking
Land Use Clearance	NavCanada	Aeronautical safety mapping and designations
Navigational Clearance	Transport Canada – Marine Division	Crossing a navigable watercourse

## **2.0 Project Information**

---

### **2.1 ENERGY SOURCES**

The Grand Renewable Energy Park will utilize wind and sunlight as sources of energy for the Project.

### **2.2 LAND OWNERSHIP**

The Project will be located on privately owned and Ontario Realty Corporation (ORC) managed lands within Haldimand County. The land that will be utilized by the Project is shown in the Project map (**Appendix A**). The legal description of the parcels of land that will be used for Project will be provided as part of the REA application.

### **2.3 PROJECT COMPONENTS**

This section provides a general description of the major equipment and infrastructure associated with operation of the Project. The preliminary project description provided in this document will be refined and finalized as Samsung proceeds through the REA process.

#### **2.3.1 Wind Turbine Generators**

The specific make and model of wind turbines to be used as part of the wind component of the Project are being finalized. They are expected to be approximately 2.2 to 2.3 MW each (nameplate capacity) for a total of 140 MW (nameplate capacity) and comprising of approximately 63 turbines. Hub height will be approximately 100 metres, with a rotor diameter of approximately 101 metres.

A more detailed description of the turbines is provided in **Appendix B**.

#### **2.3.2 Solar Panels**

The panels to be used as part of the solar component of the solar component of the Project are being finalized. They will consist of photovoltaic (PV) panels installed on fixed ground-mounted racking structures. The solar portion of the Project will have a nameplate capacity of 100 MW.

A more detailed description of the panels will be provided at a later date once the solar components are finalized.

#### **2.3.3 Electrical Interconnection**

Depending on the turbine model, a transformer (approximately 1.5 cubic metres) may be sited within approximately 3 m of the base of each tower. The transformer will be connected to the wind project's collection system, which will transport electricity to the Project's transformer substation.



Similar to the wind turbine generators, the electrical output of the solar panels will be transformed to distribution voltage levels and connected to the Project's substation via the solar project's collector system.

The substation will transform the distribution voltage of the Project's collection system to 230 kV such that it can be tied in to the provincial electricity grid operated by Hydro One Networks Inc. The substation will be operated, monitored and controlled 24-hours a day via a telecommunication system. To facilitate the Project's connection to the provincial grid, a new 30 km long (approximate) 230 kV transmission line will be constructed as part of the project. The configuration and route for the power line will be determined as part of the REA process.

#### **2.3.4 Access Laneways**

Existing provincial and municipal roads will be used to transport project-related components, equipment and personnel to the project area. The Project will be installed on a combination of private and ORC-managed lands. Access to these lands will be required for installation and operation of the wind turbines and solar panels. Because of the current farming activity in the area, numerous agricultural laneways are present in the vicinity of the Project. These existing laneways will be utilized where possible. New laneways will be constructed as required to provide access to the individual turbine sites and solar PV panels. Permanent access laneways will be approximately 4 metres wide.

#### **2.3.5 Operations and Maintenance Building**

Associated with the Project will be an operations and maintenance building. This facility will provide warehouse and workshop spaces, administrative office and telecommunications areas, equipment storage and security facilities as required.

### **2.4 PROJECT SCHEDULE**

The table below provides an overview of the projected dates associated with the Project.

**Table 2.1 Project Schedule Overview**

<b>Milestone</b>	<b>Approximate Date</b>
Initiate Public REA Process	June 2010
REA technical studies	Ongoing through to December 2010
Public Open House #1	July 2010
Draft REA Reports to Public	October 2010
Public Open House #2	December 2010
REA Approval	April 2011
Start of Construction	April 2011
Commercial Operation Date (COD)	December 2012 – March 2013
Repowering/Decommissioning	2037 (approximately 25 years after COD)

## 2.5 PROJECT ACTIVITIES

A general overview of the activities during construction, operation, and decommissioning phases of the Project are provided below.

**Table 2.2 Key Project Activities**

<b>Project Phase</b>	<b>Activities</b>
Construction	<b>Turbine and Solar Sites</b>
	Delineation of temporary work areas
	Access road construction
	Completion of necessary site grading
	Installation of tower and panel foundations
	Installation of crane pads
	Tower/turbine erection and panel installation
	Installation of step-up transformer and required wiring
	Installation of collector lines, usually parallel to access roads
	Reclamation of temporary work areas
	Site landscaping (final grading, topsoil replacement, etc.)
	<b>Substation Site</b>
	Preparation of laydown area
	Installation of substation and connection with grid
	Construction of operations and maintenance building
	Reclamation of temporary work areas
	<b>Off-Site Activities</b>
Installation of collector lines and transmission line in municipal road right of way	
Operation	<b>Turbine and Solar Sites</b>
	Preventative maintenance
	Unplanned maintenance
	Meter calibrations
	Grounds keeping
	<b>Substation Site</b>
	Preventative maintenance for substation
	Unplanned maintenance for substation
	Remote wind farm condition monitoring
	Operations and maintenance building maintenance
	<b>Off-Site Activities</b>
	Electrical line maintenance
	Decommissioning
Removal of turbine and solar panel infrastructure	
Removal of step-up transformer	
Site grading (dependent upon new proposed use)	
Possible removal of access roads dependent upon agreement with property owner	
Possible excavation and removal of collector lines depending upon agreement with property owner	
<b>Off-Site Activities</b>	
Possible removal of collector system and transmission line in municipal right of way (remove wires	

**Table 2.2 Key Project Activities**

Project Phase	Activities
	and poles)
	Disconnection of substation from provincial grid
	Removal of substation
	Removal of operation and maintenance building, dependent upon agreement with property owner

**2.5.1 Waste Generation and Emissions**

***Waste Generation***

During construction, waste material produced by the Project is expected to consist of construction material (e.g., excess fill/soil, scrap lumber, banding, plastic wrap removed from palletized goods, etc.) and a minor amount of domestic waste. Similar waste material may be generated during decommissioning.

During operation, the Operation and Maintenance Building will produce waste materials typical of an office setting, including recyclables and domestic waste. In addition, there will be waste generated as a result of ongoing maintenance activities (e.g., used lubricants and oils).

All wastes will be handled and recycled or disposed of in accordance with regulatory requirements. Further details on waste management and disposal will be developed during the REA process.

***Emissions***

During construction, dust and acoustic emissions will be generated as a result of operating heavy equipment and due to construction related traffic and various construction activities (e.g., excavation, grading, etc.). Similar emissions may be expected during decommissioning.

During operation, air emissions will be restricted to the operation of maintenance vehicles and the heating of the operation and maintenance building. Acoustic emissions from the Project (turbines, transformers and substation) will be assessed in detail during the REA process. All emissions will be managed within the limits set by regulatory requirements.

**2.5.2 Hazardous Materials**

Hazardous materials on-site are limited to fuel, lubricating oils, and other fluids associated with project construction, maintenance and operation. These materials are contained within Project components and/or the maintenance/control building. Typical containment facilities and emergency response materials will be maintained on-site as required. Disposal of any hazardous materials will be in accordance with regulatory requirements. The process for final disposal of any hazardous waste will be developed during the REA process.

**2.5.3 Sewage and Stormwater Management**

Sanitary waste generated by the construction crew will be collected via portable toilets and wash stations supplied by the construction contractor. Disposal of these wastes will be the

responsibility of the contracted party and will be done in accordance with regulatory requirements.

To support the operations and maintenance building, a septic system and water well will likely need to be installed. This system will be designed to the standard specifications for the area as defined by the MOE and/or County. More detailed information on the water well and septic system will be provided later in the REA process.

Stormwater management works may be required in association with the Operations and Maintenance building and substation. The specific requirement for these works will be assessed during the REA process.

#### **2.5.4 Water-taking Activities**

Depending on groundwater levels, some dewatering activities may be required during turbine foundation excavation; however withdrawal amounts are anticipated to be below 50,000 l/d. More information on water-taking activities will be provided later in the REA process.

### 3.0 Description of Potential Environmental Effects

---

The effects of constructing, operating, and maintaining a renewable energy facility is well understood and can be typically mitigated through well known and accepted techniques and practices. For example, siting infrastructure outside of wetlands and away from residential (sound) receptors reduces the potential for negative environmental effects.

A screening of environmental features was undertaken on potential issues and effects relevant to the Project (see **Appendix C**). Based upon the above screening of environmental features, experience gained as part Project planning, and the requirements of the REA process, the following Project-specific issues and potential effects have been identified and are expected to be further analysed as part of the REA application process:

- Heritage and Archaeological Resources
- Natural Heritage Resources
- Water Bodies
- Air, Odour, Dust
- Environmental Noise
- Land Use and Resources
- Provincial and Local Infrastructure
- Public Health and Safety

Detailed descriptions of the potential effects, mitigation measures, and net effects to these features during the construction, operation, and decommissioning phases of the Project will be provided in the REA application and summarized in the final Project Description Report.

## **4.0 Closure**

---

This report has been prepared by Stantec Consulting Ltd. for the sole benefit of Samsung, and may not be used by any third party without the express written consent of Samsung and Stantec Consulting Ltd. The data presented in this report are in accordance with Stantec's understanding of the Project as it was presented at the time of the Report.

**STANTEC CONSULTING LTD.**

**DRAFT**

---

**Rob Nadolny**  
Senior Project Manager

**DRAFT**

---

**Mark Kozak**  
Project Manager

# **Appendix A**

## **Project Location and Study Area**

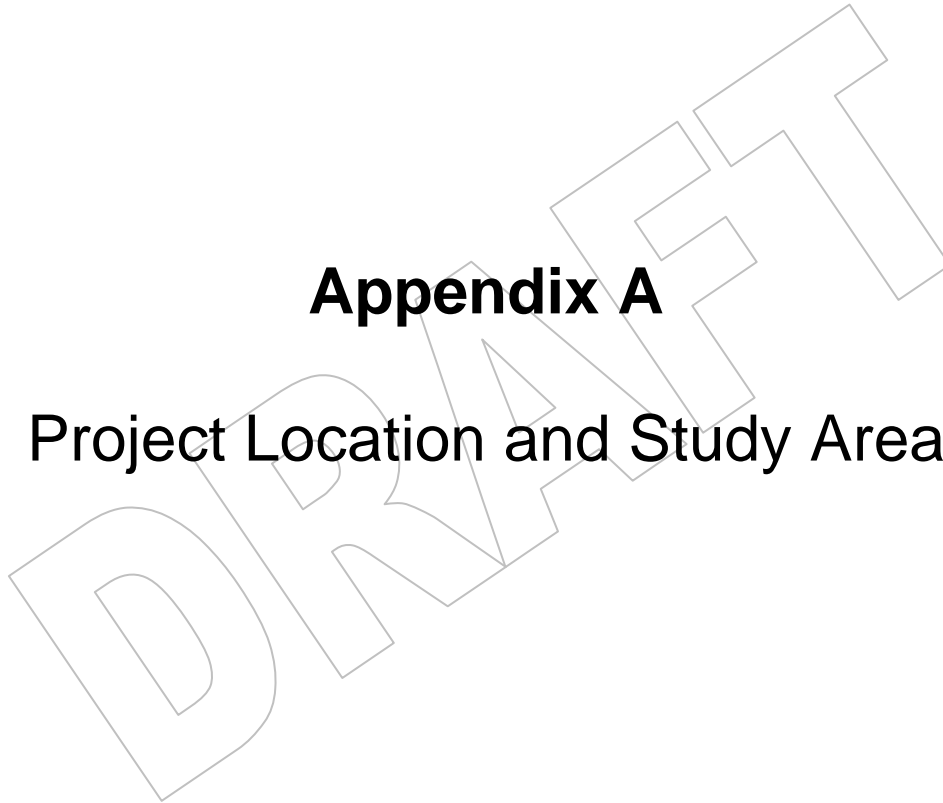

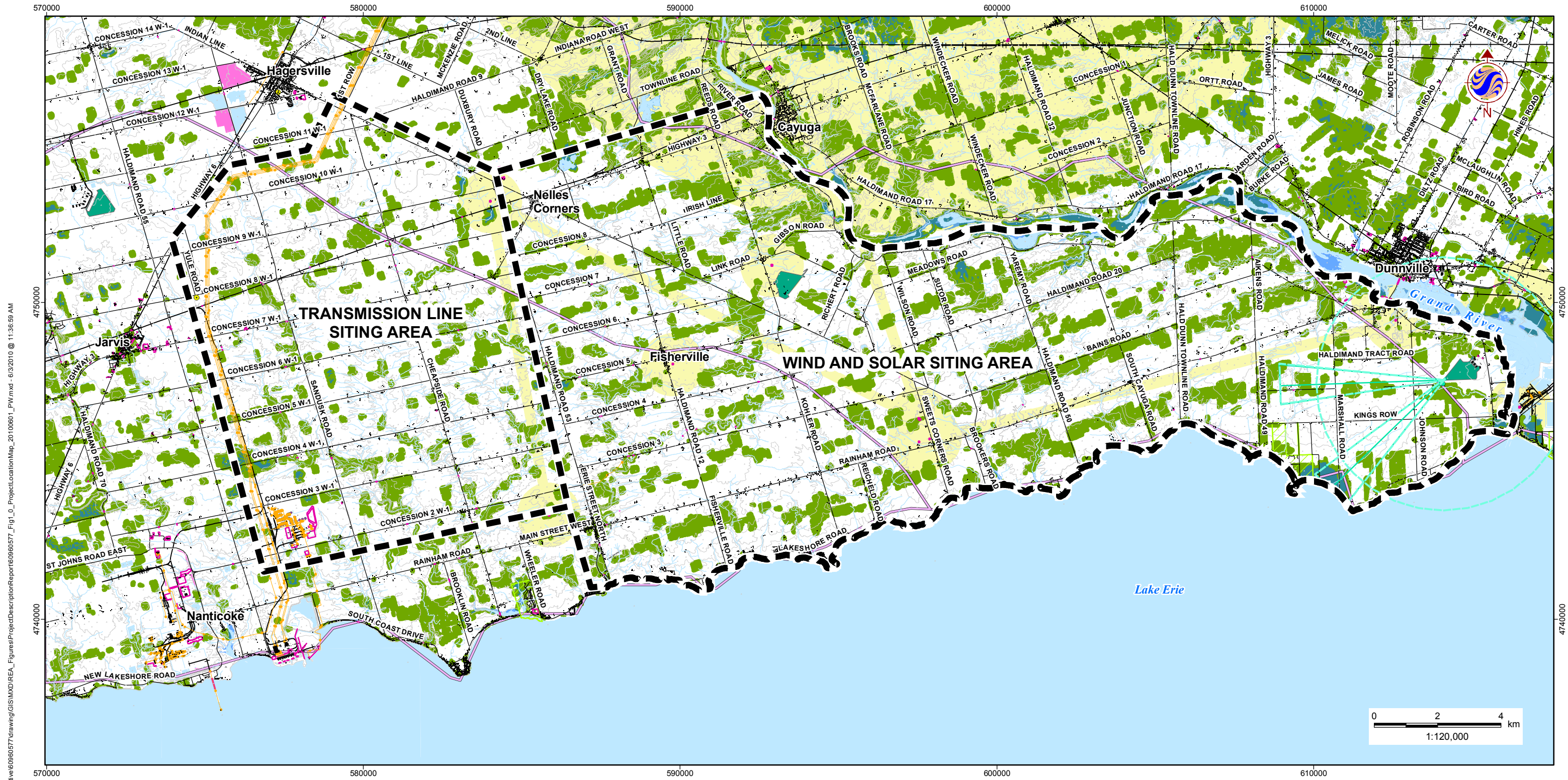

W:\active\60960577\drawing\GIS\MXD\REA\_Figures\ProjectDescription\Report\60960577\_Fig\_1\_0\_ProjectLocationMap\_20100601\_P\W.mxd - 6/2/2010 @ 11:36:59 AM

570000 580000 590000 600000 610000 4740000 4750000

May, 2010  
160960577

**Legend**

- |  |                              |  |                                       |  |                                 |
|--|------------------------------|--|---------------------------------------|--|---------------------------------|
|  | Project Location             |  | Road                                  |  | Pit or Quarry (OBM)             |
|  | Airport Runway Area Point    |  | Railway (OBM)                         |  | Wireless Communication Corridor |
|  | Airport Runway Area Polyline |  | Watercourse (OBM)                     |  | Waterbody (OBM)                 |
|  | Airport Runway Area          |  | Transmission Line (OBM)               |  | Wetland (OBM)                   |
|  | Airport (OBM)                |  | Transport Line (OBM)                  |  | Wooded Area (OBM)               |
|  | Spot Elevation Height (OBM)  |  | Building Area (OBM)                   |  |                                 |
|  | Building Point (OBM)         |  | Conservation Authority Boundary (OBM) |  |                                 |
|  | Tower (OBM)                  |  | Provincial Park (OBM)                 |  |                                 |
|  | Wireless Communication Point |  | Tank (OBM)                            |  |                                 |
|  | Contour (OBM)                |  |                                       |  |                                 |

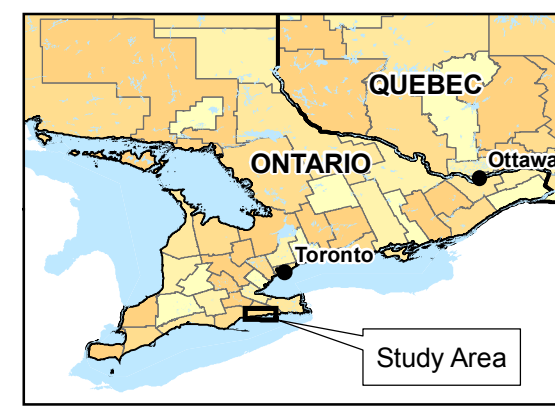

**Notes**

1. Coordinate System: UTM NAD 83 - Zone 17 (N).
2. Data Sources: Ontario Ministry of Natural Resources © Queens Printer Ontario, 2009; © GREP, 2010; © Samsung, 2010.
3. Image Sources: © Google Earth Pro, 2010 © First Base Solutions, 2010; © TeleAtlas, 2010 - Imagery Date: April 7, 2006).

Client/Project  
**SAMSUNG C&T  
GRAND RENEWABLE ENERGY PARK**

Figure No.  
**1.0**

Title  
**PROJECT LOCATION MAP**



# **Appendix B**

## **Turbine Specifications**

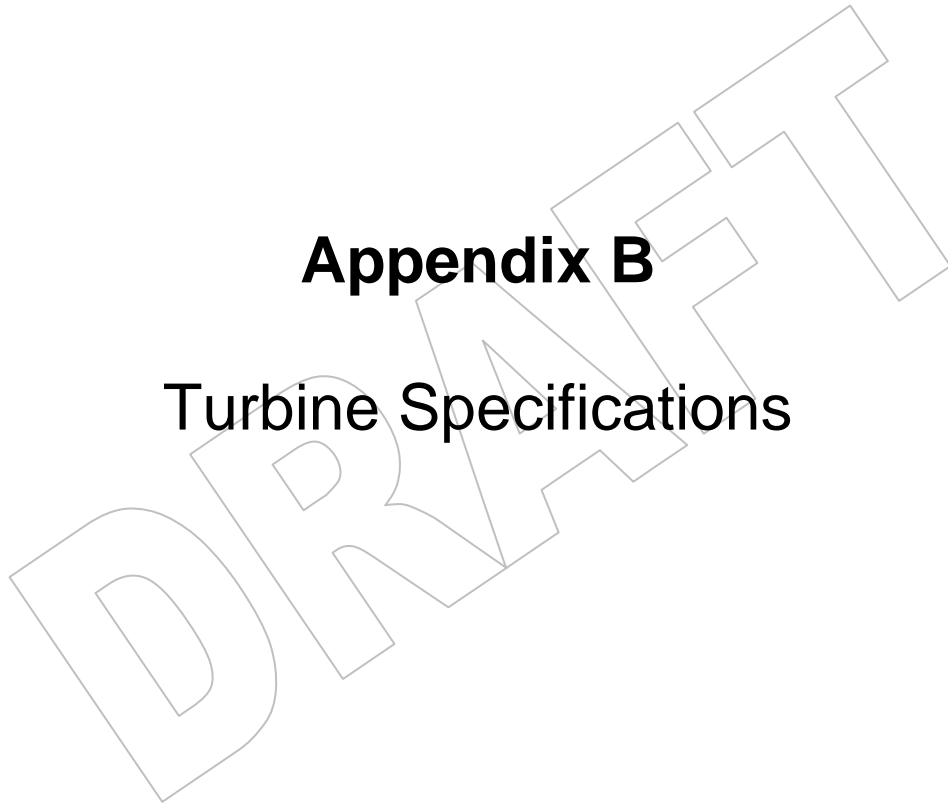

---

## SWT-2.3-101

# Technical Description

### General

The following is a brief technical description of the main components of the SWT-2.3-101 wind turbine.

### Rotor

The SWT-2.3-101 rotor is a three-bladed cantilevered construction, mounted upwind of the tower. The power output is controlled by pitch regulation. The rotor speed is variable and is designed to maximize the aerodynamic efficiency.

### Blades

The B49 blades are made of fibreglass-reinforced epoxy in Siemens' proprietary IntegralBlade® manufacturing process. In this process the blades are cast in one piece to eliminate weaker areas at glue joints. The blades are mounted on pitch bearings and can be feathered 80 degrees for shutdown purposes. Each blade has its own independent pitching mechanism capable of feathering the blade under any operating condition. The blade pitch arrangement allows for optimization of the power output throughout the operating range, and the blades are feathered during standstill to minimize wind loads.

### Rotor Hub

The rotor hub is cast in nodular cast iron and is fitted to the main shaft with a flange connection. The hub is sufficiently large to provide a comfortable working environment for two service technicians during maintenance of blade roots and pitch bearings from inside the structure.

### Main Shaft and Bearing

The main shaft is forged in alloy steel and is hollow to facilitate the transfer of power and signals to the blade pitching system. The main shaft is supported by a self-aligning double spherical roller bearing which is shrunk onto the main shaft.

### Gearbox

The gearbox is a custom-built three-stage planetary-helical design. The first high torque stage is of a helical planetary design. The two high-speed stages are of a normal helical design and provide the offset of the high speed shaft that is needed to allow passage of power and control signals to the pitch systems.

The gearbox is shaft-mounted and the main shaft torque is transferred to the gearbox by a shrink disk connection. The gearbox is supported on the nacelle with flexible rubber bushings.

The gearbox is fitted with an oil conditioning system. All bearings are lubricated with oil fed directly from a large in-line filter and is cleaned by an off-line filter unit.

The gearbox is fitted with sensors for monitoring temperature, oil pressure and vibration levels.

### Generator

The generator is a fully enclosed asynchronous generator. The generator has a squirrel-cage rotor without slip-rings. The generator rotor construction and stator winding are designed for high efficiency at partial loads.

The generator is protected with thermal switches and analogue temperature measurement sensors. The generator is fitted with a separate thermostat-controlled ventilation arrangement. Air is re-circulated internally in the generator and heat is transferred through an air-to-air heat exchanger that separates the internal environment in the generator from the ambient air.

## Mechanical Brake

The mechanical brake is fitted to the gearbox high-speed shaft and has two hydraulic calipers.

## Yaw System

The yaw bearing is an externally geared ring with a friction bearing. Eight electric planetary gear motors drive the yawing.

## Tower

The SWT-2.3-101 wind turbine is mounted on a tapered tubular steel tower. The tower has internal ascent and direct access to the yaw system and nacelle. It is equipped with platforms and internal electric lighting.

## Controller

The wind turbine controller is a microprocessor-based industrial controller. The controller is complete with switchgear and protection devices. It is self-diagnosing and has a keyboard and display for easy readout of status and for adjustment of settings.

The NetConverter® power conversion system allows generator operation at variable speed, frequency and voltage while supplying power at constant frequency and voltage to the MV transformer. The power conversion system is a modular arrangement for easy maintenance and is water cooled.

## SCADA

The SWT-2.3-101 wind turbine is equipped with the Siemens WebWPS SCADA system. This system offers remote control and a variety of status views and useful reports from a standard internet web browser. The status views present information including electrical and mechanical data, operation and fault status, meteorological data and grid station data.

## Turbine Condition Monitoring

In addition to the Siemens WebWPS SCADA system, the SWT-2.3-101 wind turbine is equipped with the unique Siemens TCM condition monitoring system. This system monitors the vibration level of the main components and compares the actual vibration spectra with a set of established reference spectra. Result review, detailed analysis and reprogramming can all be carried out using a standard web browser.

## Operation Systems

The wind turbine operates automatically. It is self-starting when the wind speed reaches an average about 3 to 5 m/s. The output increases approximately linearly with the wind speed until the wind speed reaches 11 to 12 m/s. At this point, the power is regulated at rated power.

If the average wind speed exceeds the maximum operational limit of 25 m/s, the wind turbine is shut down by feathering of the blades. When the average wind speed drops back below the restart average wind speed, the systems reset automatically.

Siemens Wind Power A/S reserves the right to change the above specifications without previous notice.

## SWT-2.3-101 Technical Specifications

### Rotor

Type .....	3-bladed, horizontal axis
Position .....	Upwind
Diameter.....	101 m
Swept area .....	8000 m <sup>2</sup>
Synchronous rotor speed .....	6-16 rpm
Power regulation .....	Pitch regulation with variable speed
Rotor tilt.....	6 degrees

### Blade

Type .....	Self-supporting
Blade length .....	49 m
Root chord.....	3.4 m
Aerodynamic profile .....	NACA63.xxx, FFAxxx, SWPxxx
Material .....	GRE
Surface gloss .....	Semi-mat, < 30 / ISO2813
Surface colour.....	Light grey, RAL 7035

### Aerodynamic Brake

Type .....	Full span pitching
Activation.....	Active, hydraulic

### Load-Supporting Parts

Hub .....	Nodular cast iron
Main bearing .....	Spherical roller bearing
Main shaft.....	Alloy steel
Nacelle bed plate .....	Steel

### Transmission System

Coupling hub - shaft.....	Flange
Coupling shaft – gearbox .....	Shrink disc
Gearbox type.....	3-stage planetary/helical
Gearbox ratio .....	1 : 91
Gearbox lubrication .....	Splash / forced lubrication
Oil volume .....	Approx. 400 l
Gearbox oil filtering .....	Inline and offline
Gearbox cooling .....	Separate oil cooler
Gearbox designation .....	PEAB 4456 (Winergy) or EH851 (Hansen)
Coupling gear - generator .....	Double flexible coupling

### Mechanical Brake

Type .....	Hydraulic disc brake
Position .....	High speed shaft
Number of callipers .....	2

### Canopy

Type.....	Totally enclosed
Material.....	Steel
Surface gloss .....	Semi gloss, 30-50, ISO2813
Colour .....	Light grey, RAL 7035

### Generator

Type.....	Asynchronous
Nominal power.....	2300 kW
Protection.....	IP 54
Cooling .....	Integrated heat exchanger
Insulation class .....	F

### Grid Terminals (LV)

Nominal power.....	2300 kW
Voltage .....	690 V
Frequency.....	50 Hz or 60 Hz

### Yaw System

Type.....	Active
Yaw bearing.....	Externally geared slewing
Yaw drive .....	Eight electric gear motors with frequency converter
Yaw brake.....	Passive friction brake

### Controller

Type.....	Microprocessor
SCADA system .....	WPS via modem
Controller designation .....	KK WTC 3.0
Controller manufacturer .....	KK Electronic A/S

### Tower

Type.....	Cylindrical and/or tapered tubular
Hub height .....	80 m or site specific
Corrosion protection .....	Painted
Surface gloss .....	Semi gloss, 30-50, ISO2813
Colour .....	Light grey, RAL 7035

### Operational Data

Cut-in wind speed. ....	4 m/s
Nominal power at .....	12-13 m/s
Cut-out wind speed .....	25 m/s
Maximum 3 s gust.....	59.5 m/s (IEC version)

### Weights (approximately)

Rotor.....	62,000 kg
Nacelle.....	82,000 kg
Tower for 80 m hub height....	162,000 kg

Siemens Wind Power A/S reserves the right to change the above specifications without previous notice.

## SWT-2.3-101 Nacelle Arrangement

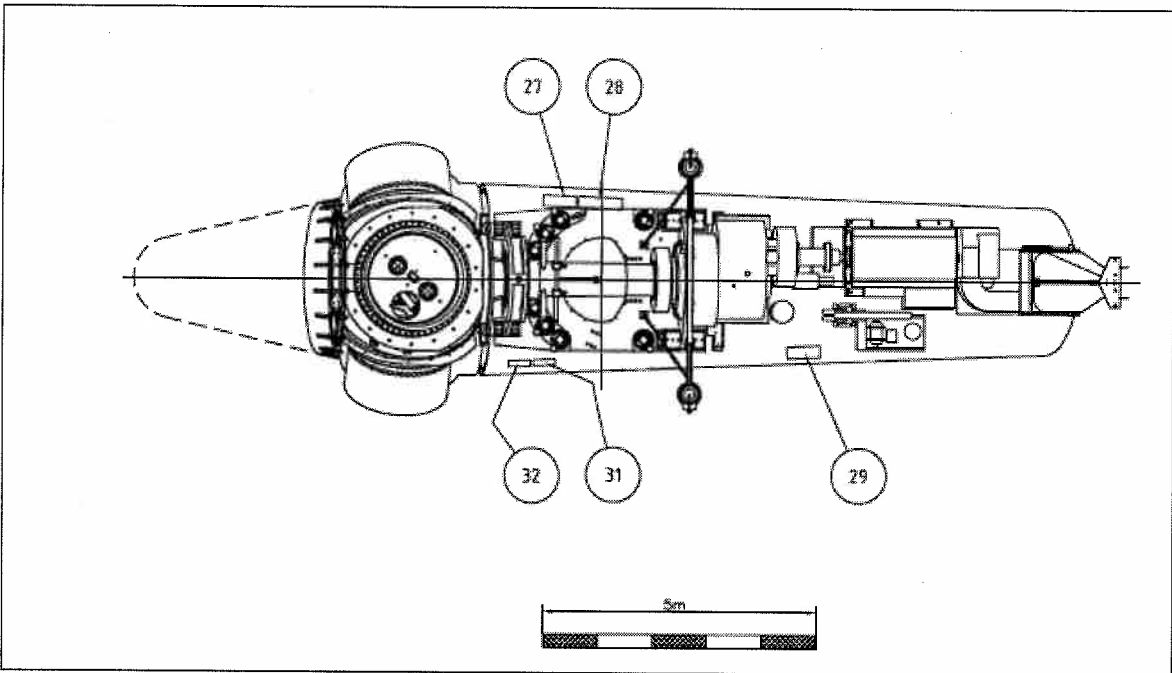
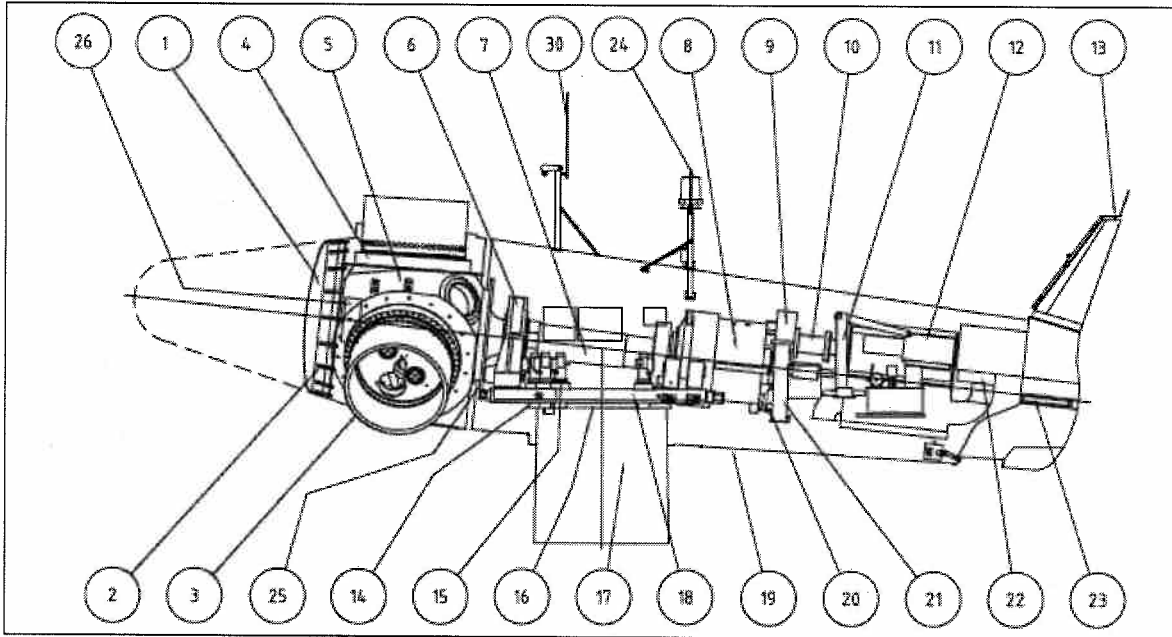

## Dansk

1. Spinner, option: lang spinner
2. Spinner beslag
3. Vinge
4. Pitchleje
5. Rotornav
6. Hovedleje
7. Hovedaksel
8. Hovedgear
9. Bremseskive
10. Kobling
11. Service kran
12. Generator
13. Meteorologiske sensorer
14. Krøjeleje
15. Krøjegear
16. Krøjerering
17. Tårn
18. Maskinramme
19. Maskinskærm
20. Oliefilter
21. Oliefilter
22. Generatorblæser
23. Oliekøler
24. Flyadvarselslys, option
  
25. Rotorlås
26. Navboks
27. Topkontrolboks
28. Relæboks
29. Forsyningsboks
30. Sigtbarehedsmåler, option
31. Kontrolboks flyadvarselslys
32. Kontrolboks sigtbarehedsmåler

## English

1. Spinner, optional long spinner
2. Spinner bracket
3. Blade
4. Pitch bearing
5. Rotor hub
6. Main bearing
7. Main shaft
8. Gearbox
9. Brake disc
10. Coupling
11. Service crane
12. Generator
13. Meteorological sensors
14. Yaw bearing
15. Yaw gear
16. Yaw ring
17. Tower
18. Nacelle bedplate
19. Canopy
20. Oil filter
21. Oil filter
22. Generator fan
23. Oil cooler
24. Aviation warning lights, option
  
25. Rotor lock
26. Hub controller box
27. Top control box
28. Relay box
29. Supply box
30. Visibility meter, option
31. Control box, aviation warning light
32. Control box, visibility meter

## Deutsch

1. Spinner, Option: langer Spinner
2. Spinnerhalterung
3. Rotorblatt
4. Blattlager
5. Nabe
6. Hauptlager
7. Hauptwelle
8. Getriebe
9. Scheibenbremse
10. Kupplung
11. Servicekran
12. Generator
13. Windfahne und Anemometer
14. Windnachführungslager
15. Windnachführung
16. Zahnkranz
17. Turm
18. Maschinenrahmen
19. Gondel
20. Öl Filter
21. Öl Filter
22. Generator Kühlung
23. Ölkühler
24. Standardhindernisbefuerung, Option
  
25. Rotor Arretierung
26. Nabencontroller
27. Top Controller
28. Relaiskasten
29. Stromversorgung
30. Sichtweitenmessgerät, Option
31. Controller, Hindernisbefuerung
32. Controller, Sichtweitenmessgerät

Siemens Wind Power reserves the right to change the above specifications without notice.

## SWT-2.3-101 Design Climatic Conditions

The design climatic conditions are the boundary conditions at which the turbine can be applied without supplementary design review. Applications of the wind turbine in more severe conditions may be possible, depending upon the overall circumstances. A project site-specific review requires the completion by the Client of the "Project Climatic Conditions" form.

Subject	ID	Issue	Unit	Value
1. Wind, operation	1.1	Wind definitions	-	IEC 61400-1 Ed3
	1.2	IEC class	-	IIB
	1.3	Air density, $\rho$	kg/m <sup>3</sup>	1.225
	1.4	Mean wind speed, $v_{ave}$	m/s	8.5
	1.5	Weibull scale parameter, A	m/s	9.6
	1.6	Weibull shape parameter, k	-	2
	1.7	Wind shear exponent, $\alpha$	-	0.20
	1.8	Mean turbulence intensity at 15 m/s, $I_{ref}$	-	0.14
	1.9	Standard deviation of wind direction	Deg	7.5
	1.10	Maximum flow inclination,	Deg	8
	1.11	Minimum turbine spacing, in rows	D	3
	1.12	Minimum turbine spacing, between rows	D	5
2. Wind, extreme	2.1	Wind definitions	-	IEC 61400-1 Ed3
	2.2	Air density, $\rho$	kg/m <sup>3</sup>	1.225
	2.3	Maximum hub height 10 min.wind, $V_{ref}$	m/s	42.5
	2.4	Maximum 3 s gust in hub height, $V_{e50}$	m/s	59.5
	2.5	Maximum hub height power law index, $\alpha$	-	0.11
3. Temperature	3.1	Temperature definitions	-	IEC 61400-1 Ed3
	3.2	Minimum temperature at 2 m, stand-still, $T_{min,s}$	Deg.C	-20
	3.3	Minimum temperature at 2 m, operation, $T_{min,o}$	Deg.C	-10
	3.4	Maximum temperature at 2 m, operation, $T_{max,o}$	Deg.C	35
	3.5	Maximum temperature at 2 m, stand-still, $T_{max,s}$	Deg.C	45
4. Corrosion	4.1	Corrosion definitions	-	ISO 12944
	4.2	External corrosion class	-	C3
	4.3	Internal corrosion class	-	C2
	4.4	Internal climate control	-	Yes
5. Lightning	5.1	Lightning definitions	-	IEC 62305-1
	5.2	Lightning protection level (LPL) acc to IEC 62305	-	LPL 1
6. Dust	6.1	Dust definitions	-	-
	6.2	Dust conditions, ground level	-	Normal DK
	6.3	Dust conditions, hub height	-	Normal DK
7. Hail	7.1	Maximum hail diameter	mm	20
	7.2	Maximum hail falling speed	m/s	20
8. Ice	8.1	Ice definitions	-	IEC 61400-1 Ed3
	8.2	Ice conditions	-	Normal DK
9. Trees	9.1	If the height of trees within 500m of any turbine location height exceeds 1/3 of $H - D/2$ where H is the hub height and D is the rotor diameter then restrictions may apply. Please contact Siemens for information on the maximum allowable tree height with respect to the site and the turbine type.		

## SWT-2.3-101, 60 Hz Application Electrical Specifications Americas

### Generator

Type .....	Asynchronous
Nominal power.....	2300kW
Speed range.....	600 - 1800 rpm
Nominal voltage.....	750V @ 1550 rpm
Nominal current.....	2070 A
Frequency .....	16,5 - 60 Hz
Protection .....	IP 54

### Generator Protection

Insulation class.....	F
Winding temperatures .....	2 x 3 PT100 sensors
Bearing temperatures.....	1 PT100 at each bearing
Bearing insulation.....	Insulation at both bearings
Grounding brush.....	On drive end

### Generator Cooling

Cooling system.....	Air to air
Ventilation.....	Shaft mounted fan
Ventilation type.....	Centrifugal
External flow direction .....	From D-end to N-end
Control parameter.....	Winding temperature

### Frequency Converter

Operation.....	4Q Full scale converter
Switching .....	PWM
Switching frequency .....	1250/2500 Hz
Cooling .....	Liquid

### Power Factor at 690 V and Nominal Grid Conditions

Power factor correction.....	Frequency converter control
Power factor range .....	0.9 cap. to 0.9 ind. at nominal balanced voltage

### Main circuit protection

Short circuit protection.....	Circuit breaker
Surge protection per phase	
$I_{max}$ (8/20 $\mu$ s) .....	30 kA

### Peak Power Levels

10 min average.....	100 % of nominal
30 sec average.....	104 % of nominal

### Grid Requirements

Nominal grid frequency.....	60 Hz
Minimum voltage .....	90 % of nominal
Maximum voltage .....	110 % of nominal
Minimum frequency .....	95 % of nominal
Maximum frequency .....	103 % of nominal
Maximum current asym. ....	5%
Max 1 s. short circuit level at controller's grid	
Terminals (690 V).....	40 kA
Min. 1 s short circuit level at controller's grid terminals (690 V).....	5 x Pn
Grid error numbers .....	Max. 300 per year

### Power Consumption from Grid (approximately)

At stand-by .....	5.0 kW, 9kVAR
At stand-by, yawing .....	9.6 kW, 9kVAR
Before cut-out (60 s).....	18 kW
After cut-out (600 s).....	18 kW

### Earthing Requirements

Earth system .....	Acc. To IEC62305-3 ED 1.0:2006
Depth electrodes .....	Min. 2 pcs 50 mm <sup>2</sup> Cu, 120° separation
Inner ring electrode.....	50 mm <sup>2</sup> Cu 1 m from tower
Outer ring electrode.....	50 mm <sup>2</sup> Cu min. 10 m from tower
Foundation reinforcement..	Must be connected to earth electrodes
Foundation terminals.....	Min. 6 stainless pads in two levels corresponding to ring electrodes, separated at 120°
HV connection .....	HV cable shield shall be connected to earthing system
Cable tray conductor .....	Min. 50 mm <sup>2</sup> bare Cu parallel to HV cable

### Transformer Requirements

Transformer impedance requirement .....	6 %
Secondary voltage.....	690 V
Vector group.....	Dyn 11 (star point earthed)

Siemens Wind Power A/S reserves the right to change the specifications without previous notice  
All data are subject to tolerances in accordance with IEC.



## SWT-2.3-101 60 Hz General 80 m Tower Arrangement

### Description

The SWT-2.3-101 wind turbine is mounted on a tapered, tubular, steel tower. The 80 m hub height tower is divided into three sections. The tower has internal ascent and direct access to the yaw system and nacelle. It is equipped with platforms and interior electric lighting.

Platforms are located just below the intermediate flange locations for suitable access to connections of cables, for tightening the bolts, and servicing the yaw system.

Siemens can substitute a functionally equivalent, rail able, tower equipment design for the standard tower equipment design set forth in this exhibit.

### Sketch of Tower Arrangement

The sketch shows the tower top, intermediate and bottoms section.

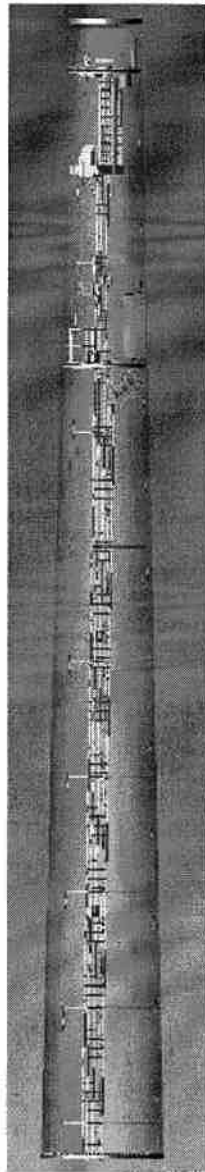

**Top Section**

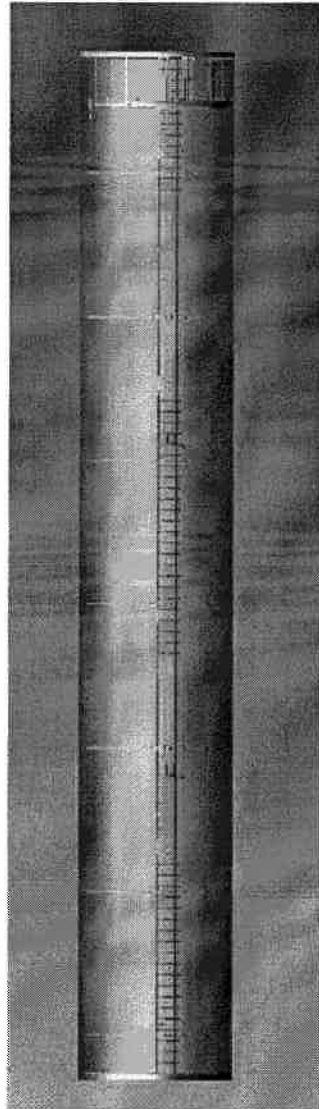

**Intermediate Section**

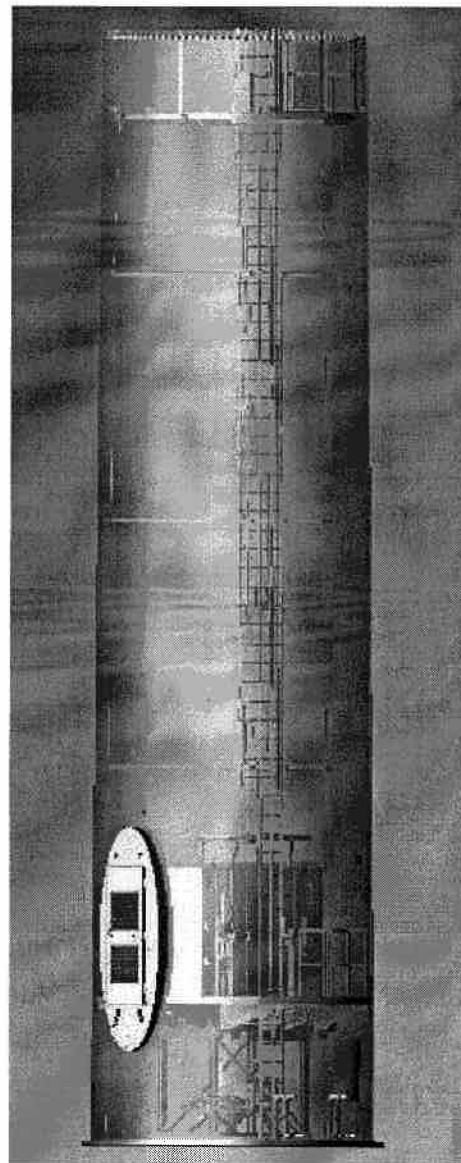

**Bottom Section**

# SWT-2.3-101, 80 m Hub Height

## Codes and Standards for

### Design, Manufacturing and Testing-Americas

The SWT-2.3-101 Wind Turbine Generator is designed, manufactured, and tested to Siemens' technical drawings, procedures, and processes that are generally in compliance with the applicable sections of the codes and standards listed herein.

#### General

- IEC WT 01:2001, IEC System for Conformity Testing and Certification of Wind Turbines. Rules and procedures
- EN 61400-1:2006, Wind turbine generator systems, Part 1: Design requirements, (IEC 61400-1:2005 Ed. 3, modified).
- IEC 61400-1:2005 Ed. 3, Wind turbine generator systems, Part 1: Design requirements.
- IEC 61400-11:1998, Wind turbine generator systems. Part 11: Acoustic noise measurement techniques.
- IEC 61400-12:1998, Wind turbine generator systems. Part 12: Wind turbines power performance testing
- DS/IEC/TS 61400-13:2002, Wind turbine generator systems, Part 13: Measurement of mechanical loads.
- DS/IEC/TS 61400-23:2002, Wind turbine generator systems, Part 23: Full-scale structural testing of rotor blades.
- DS 412:1998 Code of Practice for the structural use of steel (Weldings)
- VDI 2230 Blatt 1, February 2003, Systematic calculation of high duty bolted joints - Joints with one cylindrical bolt (Bolt calculations)
- DS-EN ISO 898-1:1999, Mechanical properties of fasteners made of carbon steel and alloy steel - Part 1: Bolts, screws and studs
- EN 10029:1993, Hot rolled steel plates 3 mm thick or above - Tolerances on dimensions, shape and mass
- DS/EN 10083:2000, Quenched and tempered steels - Part 1: Technical delivery conditions for special steels (Main shaft)
- DS/EN 1563 +A1:2004, Founding - Spheroidal graphite cast irons
- DS/EN 10025-1:2004, Hot rolled products of structural steels - Part 1: General technical delivery conditions
- DS/EN 10025-2:2004, Hot rolled products of structural steels - Part 2: Technical delivery conditions for non-alloy structural steels
- DS/EN 10025-3:2004, Hot rolled products of structural steels - Part 3: Technical delivery conditions for normalized/normalized rolled weldable fine grain structural steels
- 97/23/EF Pressure Equipment Directive

#### Gearbox

- ISO 81400-4:2005 Wind turbines – Part 4: Design and specification of gearboxes
- ISO 6336 1996, Calculation of load capacity of spur and helical gears-- Part 1 Basic principles, introduction and general influence factors (+ correction 1998 and correction 2 1999)
- ISO 6336 1996, Calculation of load capacity of spur and helical gears-- Part 2 Calculation of surface durability (+ correction 1998 and correction 2 1999)
- ISO 6336 1996, Calculation of load capacity of spur and helical gears-- Part 3 Calculation of tooth bending strength (+correction 2 1999)
- ISO 6336 2003, Calculation of load capacity of spur and helical gears-- Part 5 Strength and quality of Materials.

- ISO 281:1990, Rolling bearings – Dynamic load ratings and rating life.
- ISO 527-04:1997 Plastics - Determination of tensile properties - Part 4: test conditions for isotropic and orthotropic fiber-reinforced plastic composite: (wind turbine blades with fiberglass-reinforced epoxy)
- ASTM D3479-96, Standard Test Method for Tension-Tension Fatigue of Polymer Matrix Composite Materials (fiberglass- reinforced epoxy)\*

## Electrical

- EN61000-6-2:2005 Electromagnetic compatibility (EMC) - Part 6-2: Generic standards - Immunity for industrial environments
- EN61000-6-4: 2002 Electromagnetic compatibility (EMC) - Part 6-4: Generic standards - Emission standard for industrial environments
- EN60204-1 1998 (+correc 1999) Safety of machinery - Electrical equipment of machines - Part 1: General requirements
- EN60034-14: 2004 Rotating electrical machines - Part 14: Mechanical vibration of certain machines with shaft heights 56 mm and higher - Measurement, evaluation and limits of vibration severity (Generator)
- IEC/TR 61400-24: 2002, Wind turbine generator systems - Part 24: Lightning protection
- IEC 61400-21:2001, Wind turbine generator systems - Part 21: Measurement and assessment of power quality characteristics of grid connected wind turbines
- 2006/95/EF Low Voltage Directive
- 2004/108/EF EMC Directive
- IEEE 519-Recommended Practice and Requirements for Harmonic Control on Electric Power Systems
- FERC Order 661-A, Interconnection for Wind Energy
- The Manitoba Electrical Code – 10<sup>th</sup> Edition
- Code Red-CFE Interconnect Requirements for wind turbines to the Mexican Electrical System

## Quality

- ISO 9001:2000, Quality management systems – Requirements.

## Personal Safety

- DS/EN 50308:2005, Wind turbines – Protective measures – Requirements for design, operation and maintenance
- US Occupational, Health, and Safety (OSHA) Guidelines
- 98/37/EC Machinery Directive
- FAA AC70-7460-1K, Obstruction Marking and Lighting

## Corrosion

- DS/EN ISO 12944-1:2000, Paints and varnishes - Corrosion protection of steel structures by protective paint systems - Part 1: General introduction (class C3 to C4).

## **Appendix C**

# **Environmental Features Screening Checklist**

**Appendix C – Grand Renewable Energy Park Environmental Features Screening Checklist**

<b>1. Heritage and Archaeological Resources</b>	
1.1 Protected properties and heritage resources	<ul style="list-style-type: none"> <li>• These features may be located in the Study Area; there is potential for these features to be affected during construction.</li> <li>• A Protected Properties and Heritage Assessment will be undertaken for the Project.</li> </ul>
1.2 Archaeological resources	<ul style="list-style-type: none"> <li>• There is potential for these resources to be affected, if present, during construction.</li> <li>• Stage I and II (if recommended by the Stage I) Archaeological Assessments will be undertaken for the Project.</li> </ul>
<b>2. Natural Heritage Resources</b>	
2.1 Wetlands	<ul style="list-style-type: none"> <li>• Wetlands (provincially significant and non-provincially significant) are located in the Study Area.</li> <li>• No Project related activities will occur within provincially significant wetlands.</li> </ul>
2.2 Areas of Natural and Scientific Interest (ANSIs) – earth or life science	<ul style="list-style-type: none"> <li>• An ANSI is located within the Study Area (predominantly covering areas of the Grand River).</li> <li>• Project siting will avoid this area to the greatest extent possible.</li> </ul>
2.3 Valleylands and hazard lands	<ul style="list-style-type: none"> <li>• Valleylands and hazard lands are located within the Study Area; there is potential for these lands to be crossed with Project infrastructure, particularly watercourse crossings.</li> <li>• Mitigation measures will be implemented if avoidance is not possible in all cases.</li> </ul>
2.4 Woodlands	<ul style="list-style-type: none"> <li>• Woodlots (&gt;2ha) are located within the Study Area and there is potential for these features to be affected during construction.</li> </ul>
2.5 Provincial park and conservation reserves	<ul style="list-style-type: none"> <li>• Two provincial parks (Selkirk and James N. Allan) are located within the Study Area. No project related activities will occur within the provincial parks.</li> </ul>
2.6 Other designated natural areas	<ul style="list-style-type: none"> <li>• Ministry of Natural Resources identified deer yards are located within the Study Area and there is potential for these features to be affected during construction.</li> </ul>
2.7 Significant wildlife species or their habitat	<ul style="list-style-type: none"> <li>• The Natural Heritage Information Centre and the Ministry of Natural Resources have identified historical sightings of species at risk within the general area of study for the Project.</li> <li>• Area habitats may support such species and disruption/alteration of the habitat could cause negative effects.</li> </ul>
2.8 Other wildlife and wildlife habitat	<ul style="list-style-type: none"> <li>• Birds, mammals, amphibian and reptile species are known to use the Study Area. Construction and operation of the Project has the potential to disturb wildlife and wildlife habitat.</li> <li>• The majority of Project infrastructure will be located on lands that are already a source of disturbance to wildlife, including right-of-ways and agricultural lands.</li> </ul>

2.9 Significant flora species and vegetation communities	<ul style="list-style-type: none"> <li>• The Natural Heritage Information Centre and the Ministry of Natural Resources have identified significant flora species/vegetation communities within the general area of study for the Project.</li> <li>• There is potential to affect these species during construction, however most of the Project will be located within areas already cleared for rural and agricultural use.</li> </ul>
2.10 Other flora species and vegetation communities	<ul style="list-style-type: none"> <li>• The Project will be mostly located within areas already cleared for rural and agricultural land uses.</li> </ul>
2.11 Fish and fish habitat	<ul style="list-style-type: none"> <li>• Project related works may be within areas of fish and fish habitat (watercourse crossings). Where required, mitigation measures are available to reduce or eliminate potential effects.</li> </ul>
<b>3. Water Bodies</b>	
3.1 Surface water (watercourses) quality, quantities, or flow	<ul style="list-style-type: none"> <li>• Watercourses are located throughout the project and the Study Area is bordered by Lake Erie to the south. There are no Lake Trout lakes that are at or above development capacity within the Study Area.</li> <li>• Construction (e.g., culverts for access road crossings) may be proposed within surface water courses and limited works (e.g. stringing overhead power lines) may be proposed within 30 metres of a watercourse.</li> <li>• The proposed development does not involve the storage or consumption of surface water.</li> <li>• The proposed development will not require significant alteration of surface runoff patterns.</li> <li>• Surface water quality could be affected by accidental spills/releases to the environment and sedimentation and/or erosion during construction of access roads.</li> </ul>
3.2 Groundwater quality, quantity, or movement	<ul style="list-style-type: none"> <li>• It is possible that some dewatering activities may be required when installing Project infrastructure (i.e., foundations).</li> <li>• Withdrawal quantities will be below the threshold for a Permit to Take Water from the MOE (i.e., &lt;50,000 l/d) and will not negatively affect groundwater quality or quantity.</li> <li>• Groundwater quality could be affected by accidental spills/releases to the environment.</li> </ul>
<b>4. Air, Odour, Dust</b>	
4.1 Emissions of oxides of nitrogen (“NO <sub>x</sub> ”), sulphur dioxide (“SO <sub>2</sub> ”), total suspended particulates (“TSP”), or other pollutants	<ul style="list-style-type: none"> <li>• Reciprocating engine equipment (e.g., excavators and haulage trucks) will be used during the construction phase of the Project; however this will be short in duration and limited in extent</li> <li>• Operation of the Project will not result in negative effects on air quality since no emissions of NO<sub>x</sub>, SO<sub>2</sub>, TSP, or particulate matter are generated by the wind turbines and solar panels.</li> </ul>
4.2 Emission of greenhouse gases (carbon dioxide and methane)	<ul style="list-style-type: none"> <li>• Emissions of carbon dioxide or methane will be generated by construction equipment; however this will be short in duration and limited in extent.</li> </ul>
4.3 Emission of dust or odour	<ul style="list-style-type: none"> <li>• During construction dust may be generated from earthmoving or vehicular activity – any emissions will be short in duration and limited to the lands surrounding the work areas.</li> </ul>



5. Noise	
5.1 Emission of noise	<ul style="list-style-type: none"> <li>• Mechanical and aerodynamic noise will be emitted from the wind turbines and transformer substation.</li> <li>• There is potential for limited environmental noise effects at sensitive receptors.</li> <li>• For the wind portion of the project, a detailed environmental noise impact assessment will be undertaken as per the MOE's document <i>Noise Guidelines for Wind Farms - Interpretation for Applying MOE NPC Publications to Wind Power Generation Facilities (October 2008)</i>.</li> </ul>
6. Land-Use and Resources	
6.1 Existing land uses	<ul style="list-style-type: none"> <li>• Project is located in a predominantly rural and agricultural area.</li> <li>• Lands for project infrastructure will be required for the lease period.</li> <li>• During the lease period these lands will be changed from their present land-use.</li> </ul>
6.2 Local businesses and facilities	<ul style="list-style-type: none"> <li>• Area businesses will benefit financially from construction activities and fulfilling operational supplies.</li> </ul>
6.3 Recreation areas	<ul style="list-style-type: none"> <li>• Construction activities will not directly affect recreation areas.</li> <li>• No effects are anticipated during the operation phase.</li> </ul>
6.4 Landfill sites	<ul style="list-style-type: none"> <li>• Construction wastes, such as excavated soils, equipment packaging and wrappings, and scraps, will be produced.</li> <li>• The Project will generate waste associated with turbine construction, maintenance and operation, and decommissioning.</li> <li>• No negative effects are anticipated on local landfill sites.</li> </ul>
6.5 Canada Land Inventory Class 1-3 (i.e., prime agricultural lands), specialty crops, or locally significant agricultural lands	<ul style="list-style-type: none"> <li>• Project infrastructure will occupy areas of prime agricultural land.</li> <li>• The operation of the project will not negatively affect the use of adjoining prime agricultural lands, field crop production, or livestock pasturing, all of which can occur in close proximity to the project.</li> <li>• The 2005 PPS contains policies that support the establishment of renewable facilities in rural and agricultural areas.</li> </ul>
6.6 Mineral, aggregate, or petroleum resources	<ul style="list-style-type: none"> <li>• There are known petroleum resources within the study area.</li> <li>• There is a designated aggregate resource license within the lands proposed for the Project.</li> </ul>
6.7 Forest resources	<ul style="list-style-type: none"> <li>• Construction of the project will not affect any merchantable forest resources.</li> </ul>
6.8 Game and fishery resources, including creating access to previously inaccessible areas	<ul style="list-style-type: none"> <li>• The area is largely cleared for agriculture and there are no areas that could be deemed inaccessible.</li> <li>• There are potential fisheries resources that may be affected by the construction of the Project (e.g., possibility of limited drainage ditch crossings).</li> </ul>
6.9 Remediation of contaminated land	<ul style="list-style-type: none"> <li>• History of the area is rural and agricultural, therefore there is limited potential for contaminated sites, however, the possibility of encountering such lands cannot be completely ruled out.</li> </ul>

6.10 Telecommunications network	<ul style="list-style-type: none"> <li>• There is potential to interfere with telecommunications networks in the Study Area.</li> <li>• Consultation with appropriate agencies regarding potential effects to these systems will be undertaken for the Project.</li> </ul>
<b>7. Provincial and Local Infrastructure</b>	
7.1 Provincial infrastructure	<ul style="list-style-type: none"> <li>• Potential for an increase of traffic during construction on provincial roads due to commuting workforce and the transport of equipments and supplies.</li> <li>• Other provincial infrastructure in proximity to the Project location will be identified.</li> </ul>
7.2 Local infrastructure and services	<ul style="list-style-type: none"> <li>• The transport of equipment and supplies during the construction phase will result in additional (temporary) road use and traffic to the Project sites carrying excess loads and large tower components.</li> <li>• Numerous trucks trips will be required for equipment transportation during Project construction.</li> <li>• During operation supplies will be intermittently delivered to the Project as required.</li> <li>• Other local infrastructure in proximity to the Project location will be identified.</li> <li>• The construction period will result in additional demand for local goods and services.</li> <li>• A limited number of operating personnel may be required to maintain the facility; therefore there will be only a nominal demand on/for public services (e.g., housing, hospitals, and schools).</li> <li>• To the extent possible local goods and services will be procured during construction, operation and maintenance and decommissioning of the Project where these are available in sufficient quantity and quality and at competitive prices – creating a positive economic effect.</li> </ul>
<b>8. Public Health and Safety</b>	
8.1 Public health and safety	<ul style="list-style-type: none"> <li>• Potential exists for accidents and malfunctions and thus there may be general public safety concerns with the new infrastructure.</li> <li>• There is no scientific evidence, to date, to demonstrate a causal association between wind turbine noise and adverse health effects.</li> <li>• The Project will not contribute green house gases or other atmospheric pollutants and thus no public health concerns have been identified.</li> </ul>
<b>9. Areas Protected under Provincial Plans and Policies</b>	
9.1 Greenbelt (Protected Countryside and Natural Heritage System), Oak Ridges Moraine Conservation Plan Area, Niagara Escarpment Plan Area, Lake Simcoe Watershed Plan Area	<ul style="list-style-type: none"> <li>• No areas protected under Provincial Plans and Policies are located within the Study Area.</li> </ul>
<b>10. Aboriginal</b>	
10.1 First Nations or other Aboriginal communities	<ul style="list-style-type: none"> <li>• Aboriginal communities have been and will continue to be engaged as part of project planning.</li> </ul>

**11. Other**

11.1 Aeronautical obstruction	<ul style="list-style-type: none"><li>• Some of the wind turbines may require aviation safety lighting.</li></ul>
11.2 Interference with navigable waters	<ul style="list-style-type: none"><li>• Project may cross or affect potentially navigable waterways. Confirmation will be obtained from Transport Canada.</li></ul>

DRAFT